



Innovative Technology

INTELLIGENCE IN VALIDATION

NV11 Spectral

“Market leading, compact note recycler”



- Full note high resolution imaging - 1.28 million data points
- Optical and mechanical anti-strimming technology
- Significantly reduces operational costs
- Maximises operational efficiency



FEATURES

- 30 note single denomination recycler
- Optical and mechanical anti-strimming technology
- Dramatically reduces coin float levels
- Easy maintenance, free firmware updates
- All notes in the Note Float can be transferred to the cashbox for easy collection



BENEFITS

- Maximises cash efficiency and reduces coin starvation
- Unrivalled genuine note detection & protection against fraudulent notes
- Significantly lowers operational costs
- Future proof - quick & easy updates via USB, PC or handheld programmer
- Lowest operator collection costs



Innovative Technology

INTELLIGENCE IN VALIDATION

Technical Specification

Power

Requirements: 12V

Standby: 350mA

Running: 3A

Peak: 3.5A

Protocols

SSP MDB

ccTalk

Interfaces

USB

Open Collector

Note Dimensions

Width: 60 - 82 mm

Length: 115 - 150 mm

Recycler Capacity

30 notes

Bezel Options

82mm horizontal

82mm chamfered

Rainbow illumination

Cashbox Options

300 standard

300 lockable

300 / 600 slide

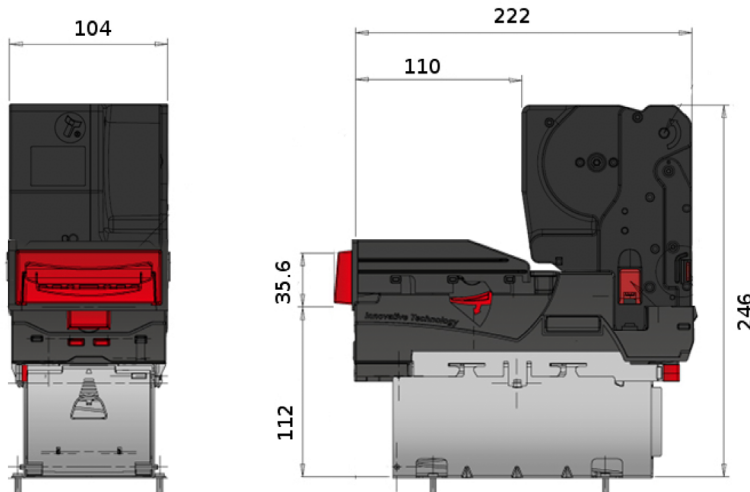

- Weight: 2.2kg

**VIEW MORE
NOTE HANDLING
PRODUCTS >>**



Find Us

Head Office

Innovative Technology Ltd (UK)

Innovative Business Park

Derker Street

Oldham

OL1 4EQ



Telephone

+44 (0) 161 626 9999



Email

sales@innovative-technology.com