



Innovative Technology

INTELLIGENCE IN VALIDATION

NV11+

"Market leading, compact bill recycler"

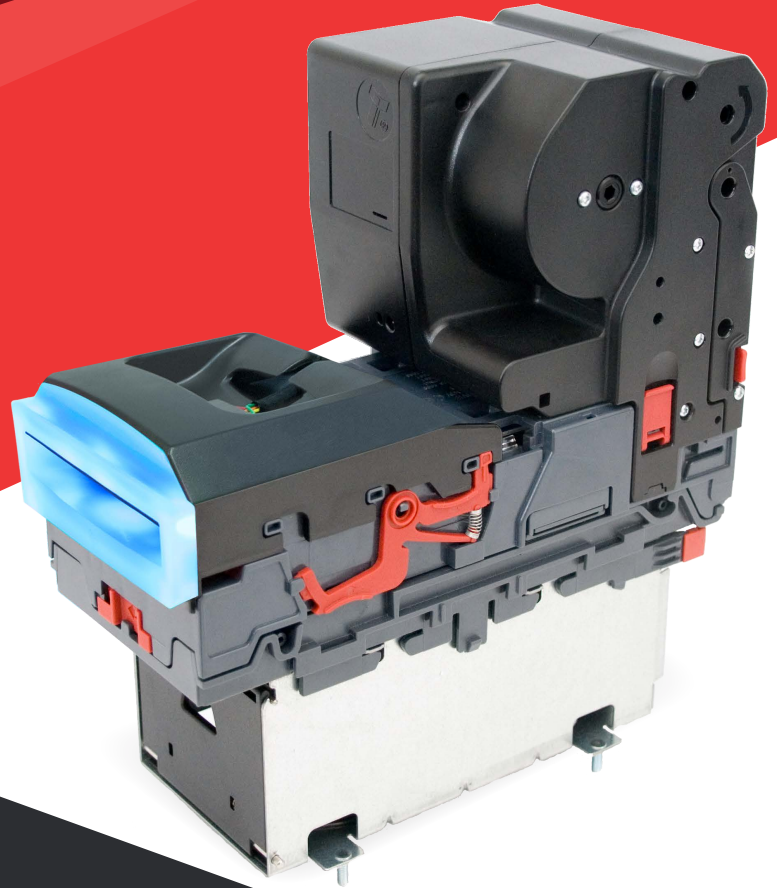

- Market leading compact bill recycler
- Proven field reliability
- Significantly reduces operational costs
- Maximises operational efficiency



FEATURES

- 30 bill single denomination recycler
- Proven field reliability
- Dramatically reduces coin float levels
- Easy maintenance, free firmware updates
- All bills in the float can be transferred to the Note Float for easy collection



BENEFITS

- Maximises cash efficiency and reduces coin starvation
- Lowest cost of ownership
- Significantly lowers operational costs
- Future proof - quick & easy updates via USB, PC or handheld programmer
- Lowest operator collection costs



Innovative Technology

INTELLIGENCE IN VALIDATION

Technical Specification

Power

Requirements: 12V

Standby: 350mA

Running: 3A

Peak: 3.5A

Protocols

SSP
ccTalk
MDB

Interfaces

USB

Open Collector

Bill Dimensions

Width: 60 - 82mm

Length: 115 - 150mm

Recycler Capacity

30 bills

Bezel Options

82mm horizontal

82mm chamfered

Rainbow illumination

Cashbox Options

300 standard

300 lockable

300 / 600 slide

Stackerless

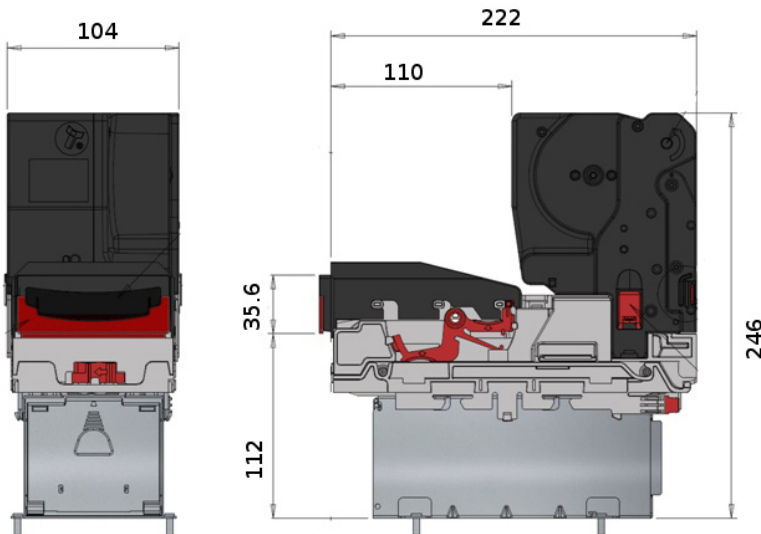

- Weight: 2.2kg

**VIEW MORE
NOTE HANDLING
PRODUCTS >>**



Find Us

Head Office

Innovative Technology Ltd (UK)

Innovative Business Park

Derker Street

Oldham

OL1 4EQ



Telephone

+44 (0) 161 626 9999



Email

sales@innovative-technology.com